

1. Gate legs

4 x Legs
630x48x48mm

4 x Short Rails
270x48x48mm

2. Table Frame

2 x Front & Back Long Rails
1445x48x48mm

4 x Short Rails
280x48x48mm

2 x Support Blocks
245x48x48mm

1 x Long Front Slat
1582x48x20mm

6 x Intermediate slats*
598x48x20mm

*Not required if no grill is set in.

1 x Back Slat
1450x48x20mm

3. Upright Supports

2 x Main Back Uprights
1640x48x48mm

3 x Braces
1546x60x20mm

1 x Lower Pivot Point Block
350x48x48mm

Cut in half to make two when drilled.

1 x Top Pivot Point Block
96x48x48mm

Cut in half to make two when drilled.

4. Lower Frame

2 x Front & Back Rails
1450x48x20mm

4 x Short Rails
270 x 48 x 48mm

2 x Front & Back Slats
1450x48x20mm

3 x Inter Slats
1548x48x48mm

AXMINSTER TOOLS

We share your passion.

**Potting Table
Cutting List**

*If you are not including a grill in your design, then 4 x slats can be used instead.

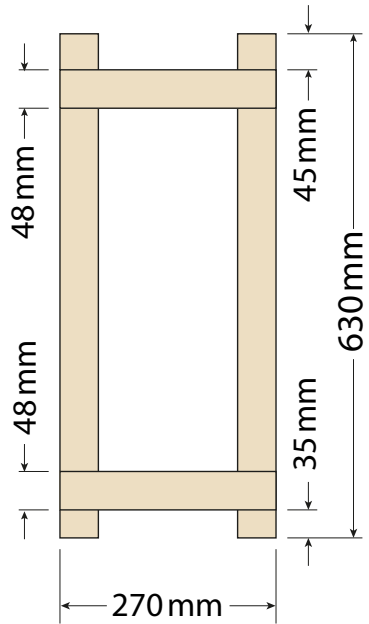

1. Gate Legs

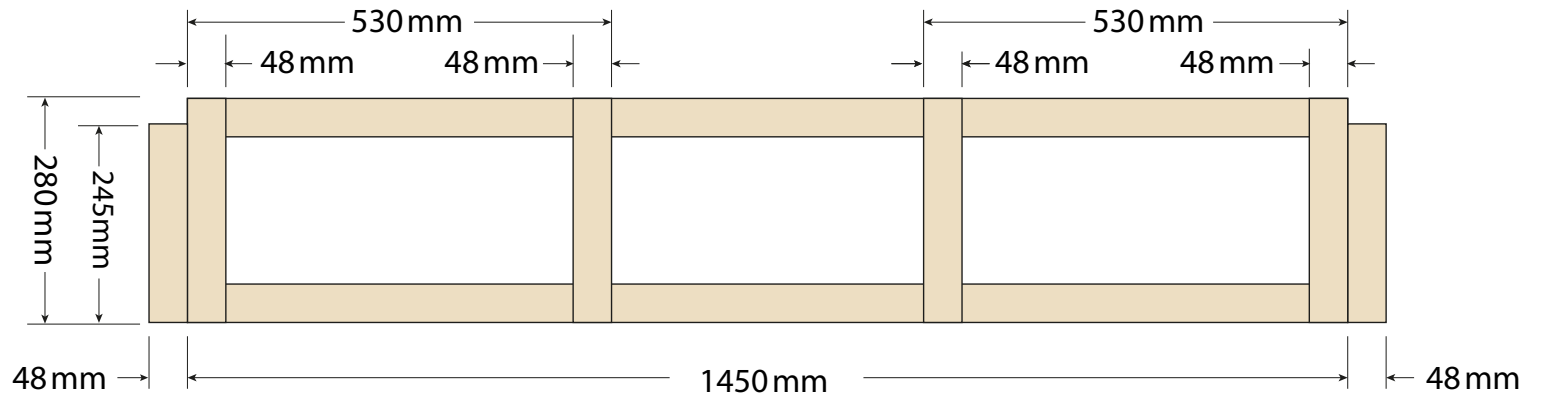

2. Table Frame

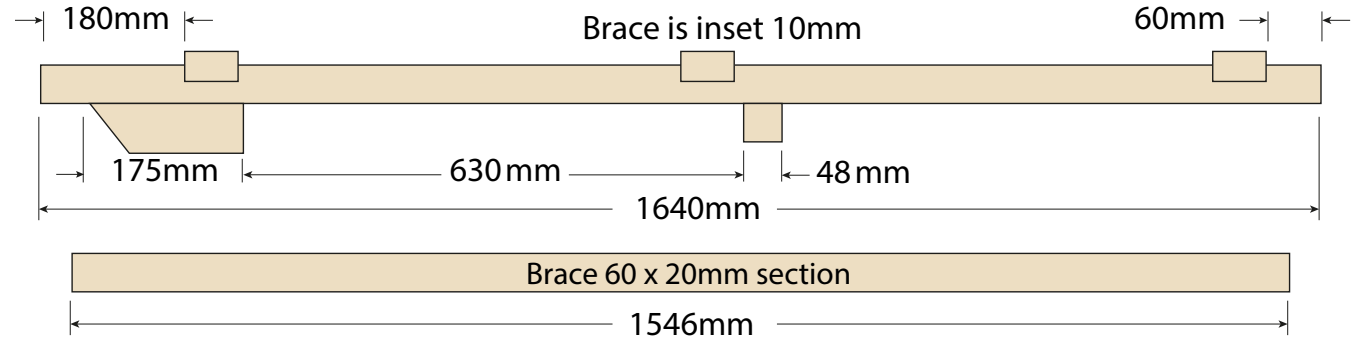

3. Upright Supports

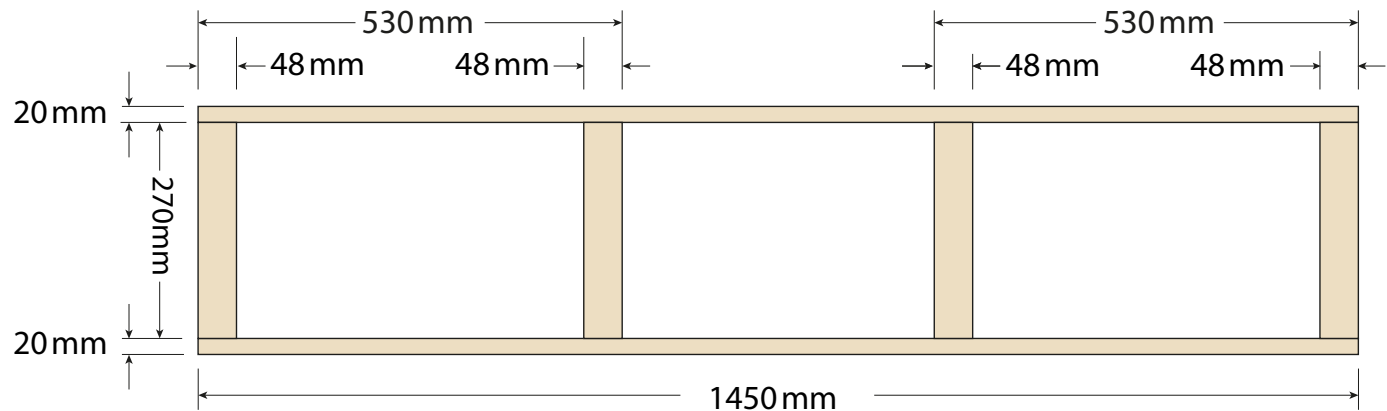

4. Lower Frame

AXMINSTER TOOLS

We share your passion.

**Potting Table
Frames**

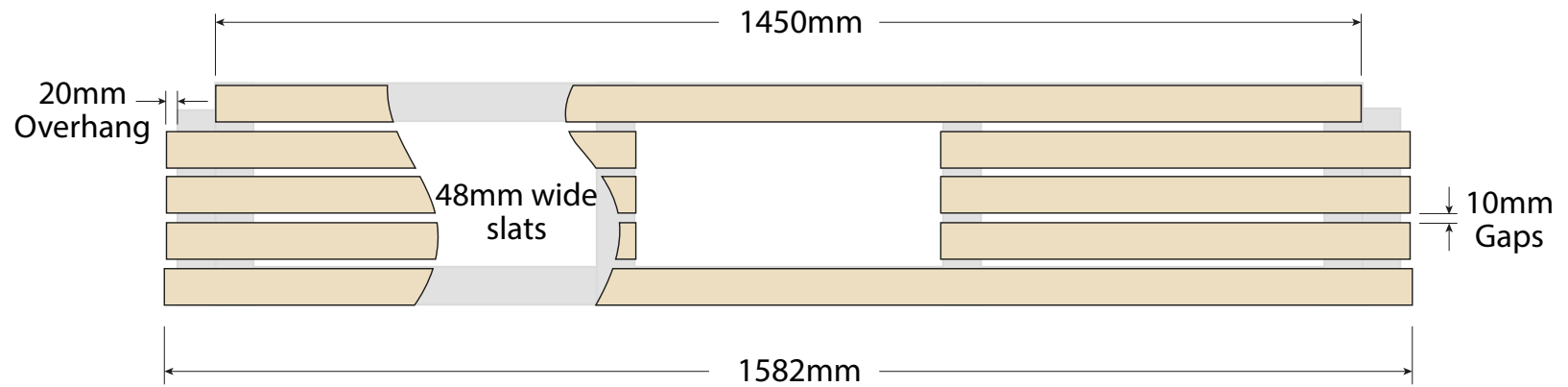

2. Table Frame Slats

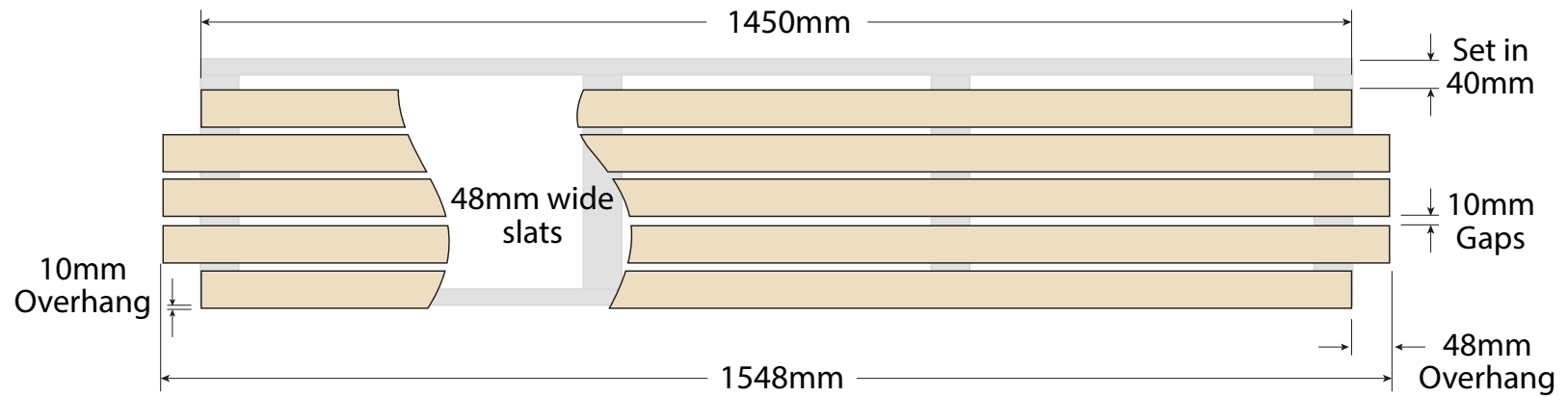

4. Lower Frame Slats

AXMINSTER TOOLS

We share your passion.

**Potting Table
Slats**